

## BITZER Railroad Scale

Concrete's quality:	C 45 / 55
Installation height:	1,30 m
Scope of weighing:	on customer request
Partition:	20 kg
Length:	flexible
Width:	2,10 m
Accuracy:	legal for trade, in accordance with EC-Directive 2009/23/EG, DIN EN 45501 (OIML R 76-1), Scale for trade class III

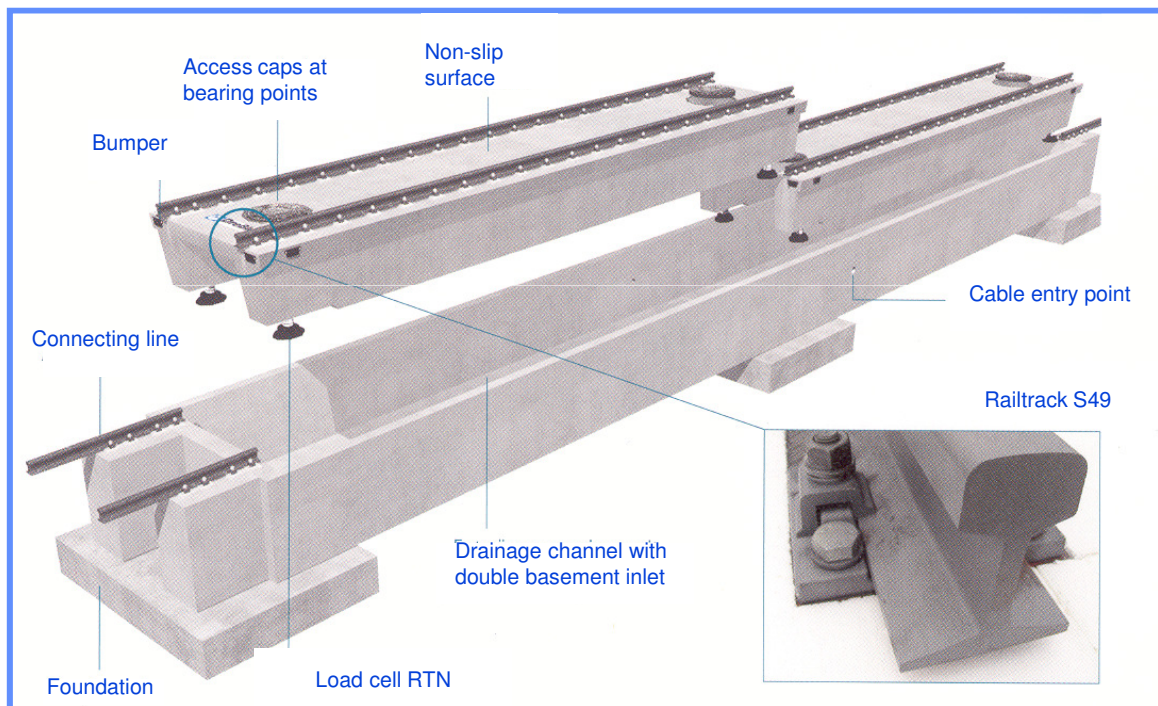

### Torsion load cells RTN

- ▲ legal for trade execution Ausführung according OIML
- ▲ high accuracy, even in very small application range
- ▲ major output signal and therefore high-resolvable wanted signal
- ▲ application in EX-area with protection class EEx ib IIC T 6
- ▲ protection class IP 68